



User Manual

ECAIA ionizer S
ECAIA ionizer S+



Water Treatment Device



International sales through:

SANUSLIFE INTERNATIONAL GmbH
Via Luigi Negrelli 13/C, 39100 Bolzano (I)
Tel.: +39 0471 979998

www.sanusproducts.com – support@sanusproducts.com



Table of Contents

	ECAIA ionizer S / ECAIA ionizer S+	4
A	Scope of delivery ECAIA ionizer S	5
B	Name and description of individual parts	6
1	Installation (water inlet connector and device configuration)	8
1.1	Using the quick release fastener	8
1.2	Sieve for tap water supply hose.....	9
1.3	Temporary connection to the water tap	9
1.4	Permanent connection to the angle valve (appliance in above-counter position) ...	10
1.5	Permanent connection to the angle valve (ECAIA ionizer S+; appliance in below-counter position; using the additional ECAIA ionizer S faucet).....	12
1.6	ECAIA ionizer S wall mounting	12
1.7	Assembly of the alkaline outlet hose and the acidic water tap	13
1.8	Before use	14
1.9	Language settings	14
1.10	Volume configuration	15
1.11	Flow rate configuration	16
1.12	Description of the buttons	17
1.13	Control of the ionization performance	18
1.14	Setting ionization performance	19
1.15	Lower water outlet (B-12) configuration	21
2	ECAIA water production	22
2.1	Alkaline ionized water	22
2.2	Acidic ionized water	23
2.3	Filtered water only	23
2.4	Proper use of ECAIA water	24
3	Filter and filter replacement	25
3.1	Filter shelf-life	25
3.2	Filter replacement	26
4	Maintenance and care	28
4.1	Self-cleaning function	28
4.2	Descaling	29
4.3	Cleaning and disinfection	32
5	Safety instructions	33
6	Error and problem handling	35
7	FAQs	37
7.1	When should you measure the pH value of the ECAIA water?	37
7.2	Does the ECAIA ionizer S also work with hard water?	37
7.3	Does the ECAIA ionizer S also work when using a descaling system?	37
7.4	What is the ORP value or the redox potential?	37
7.5	Can bacteria accumulate in the ECAIA ionizer S and thus contaminate the water?	38
7.6	Does the ECAIA ionizer S also filter limescale?	38

7.7	White residue or deposits form on glassware. How can that be?	38
7.8	What happens if you drink too much ECAIA water? Can it have negative effects on health?	38
7.9	Hardly any water comes out, what can I do?	39
7.10	Why does warm water comes out of the ECAIA ionizer S?	39
7.11	Is it possible to use own water source?	39
8	Technical specifications	40
9	Warranty and guarantee	41
10	Customer service form	43
11	Certificates	45

ECAIA ionizer S / ECAIA ionizer S+*

Water Treatment Device

This is the complete user manual (full version).

Please read the instruction manual carefully. Print it out. Keep it close to your appliance so that you can have it at hand quickly if necessary and refer to it immediately if you have any questions or if error messages have been displayed.

The manufacturer and distribution company SANUSLIFE INTERNATIONAL GmbH will not be held responsible for any malfunction or accidents resulting from incorrect installation, improper handling and/or maintenance.







It is recommended to have the ECAIA ionizer S installed by a competent installer according to the instructions given in the complete instruction manual. After completing the installation, read the complete instruction manual carefully in order to make all settings correctly.

Before operating the appliance, check that no water is leaking, that it is working properly and that the water flow is adjusted correctly. Please do not tilt the appliance. This may cause the electronic components inside the appliance to become wet or damaged.

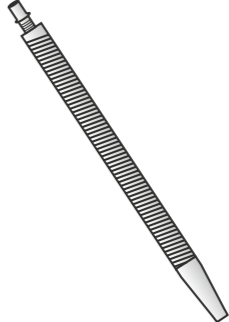
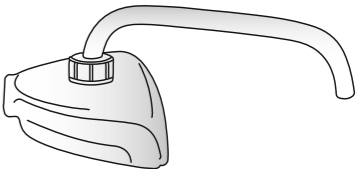
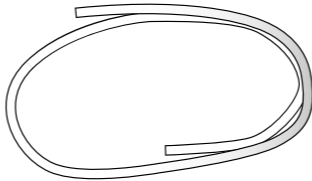
Please note that the ECAIA ionizer S is an appliance for the treatment of cold drinking water. Depending on the quality of your tap water, the performance of the appliance may vary.

* If the ECAIA ionizer S is used in combination with the additional ECAIA ionizer S faucet, toggle the control electronics so that all controls work via the buttons of the ECAIA ionizer S faucet. The device in this mode is referred to in the user manual as the ECAIA ionizer S+.

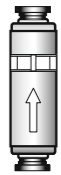
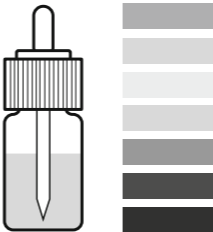
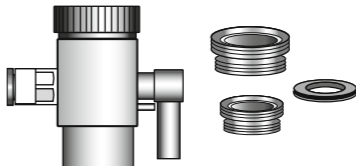
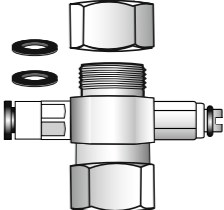
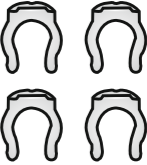
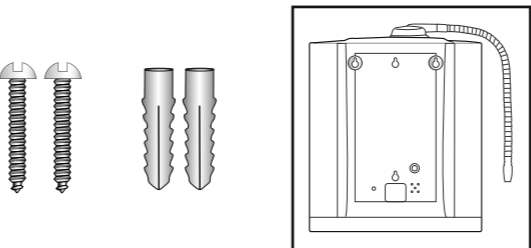
A Scope of delivery ECAIA ionizer S

<p>① ECAIA ionizer S including Filter No. 1 and Filter No. 2</p> 	<p>② Alkaline water flexible discharge hose</p> 	<p>③ Acidic water tap</p> 	
<p>④ Plastic hose for acidic water 7/9 mm</p> 	<p>⑤ Clamp for plastic hose</p> 	<p>⑥ Tap water supply hose 1/4"</p> <p>(X) </p> <p>(O) </p>	<p>⑦ Filter for tap water supply hose 1/4"</p> 
<p>⑧ Indicator liquid for pH value measurement including pH scale</p> 	<p>⑨ Diverter valve with aerator inclu- ding internal thread and seal for connection to water tap with stan- dard thread</p> 	<p>⑩ T-piece for connection to angle valve 3/8"</p> 	<p>⑪ Safety clips for quick-release fastener (4 x 1/4")</p> 
<p>⑫ Accessories for wall mounting including installation diagram</p> 		<p>⑬ Replacement fuse (2 A)</p> 	<p>⑭ Instruction manual (Short version)</p> 



If you have any further questions, please contact the Support Team of SANUSLIFE INTERNATIONAL. You can find the contact details on the SANUSLIFE INTERNATIONAL website www.sanusproducts.com

B Name and description of the individual parts

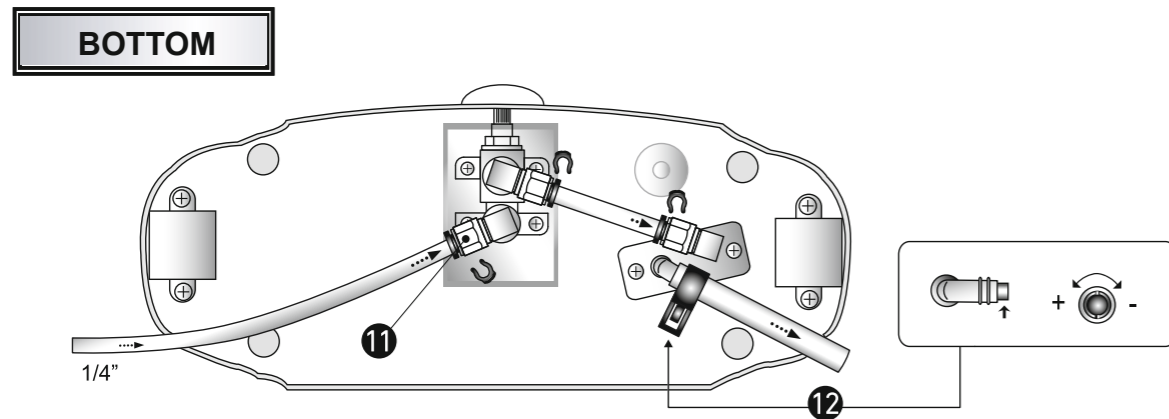
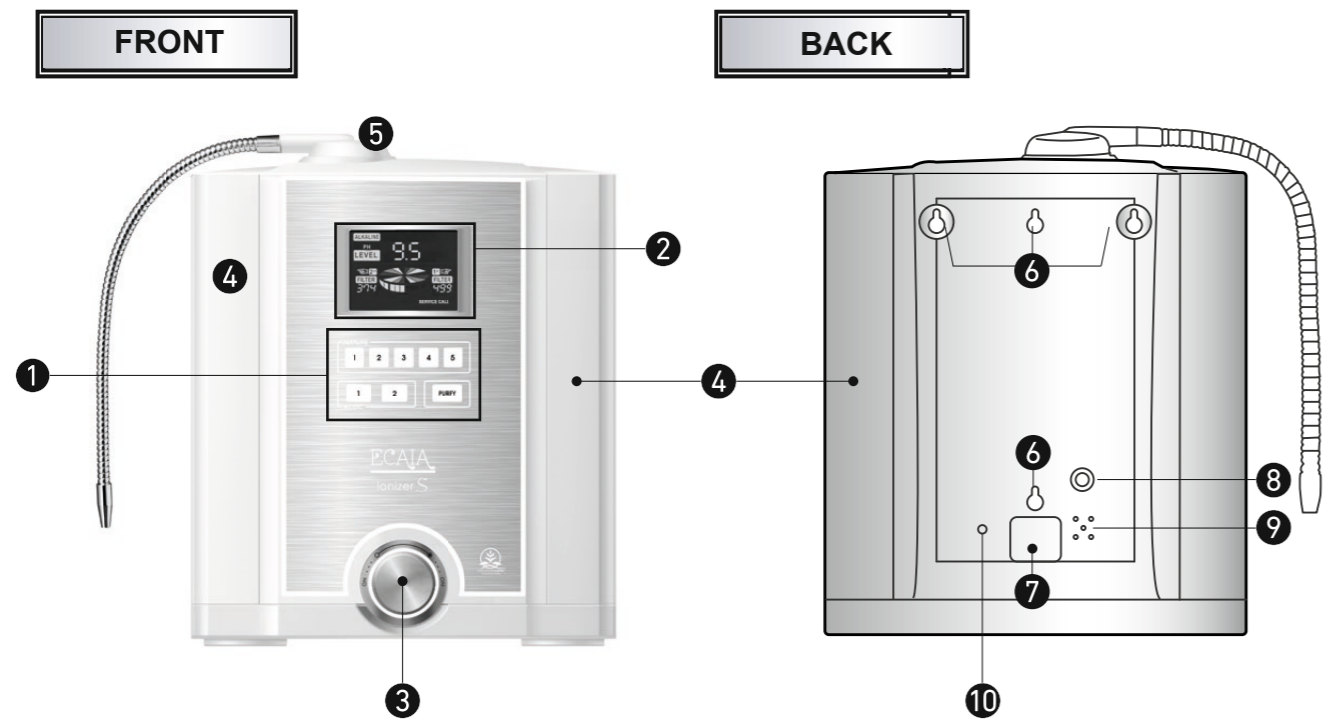

- | | | |
|----|---------------------------|---|
| 1 | Control panel | Buttons for program selection |
| 2 | Display | Display of the functions |
| 3 | Water flow rate regulator | To switch the appliance on and off and to regulate the water flow rate |
| 4 | Filter cover | Protective cover for the filters |
| 5 | Upper water outlet | Alkaline water outlet (acidic water outlet if the ACID program has been selected) |
| 6 | Wall mounting groove | For wall mounting using screws and dowels |
| 7 | Connection cover | To connect the control cable of the optional faucet (mounted under the sink) |
| 8 | Fuse holder | Fuse for overvoltage protection |
| 9 | Speaker | For the output of acoustic signals |
| 10 | Audio volume control | Volume control of the acoustic signals |
| 11 | Water inlet | Connection to tap water supply hose 1/4" (A-6) |
| 12 | Lower water outlet | Acidic water outlet (alkaline water outlet if the ACID program has been selected) |

DISPLAY

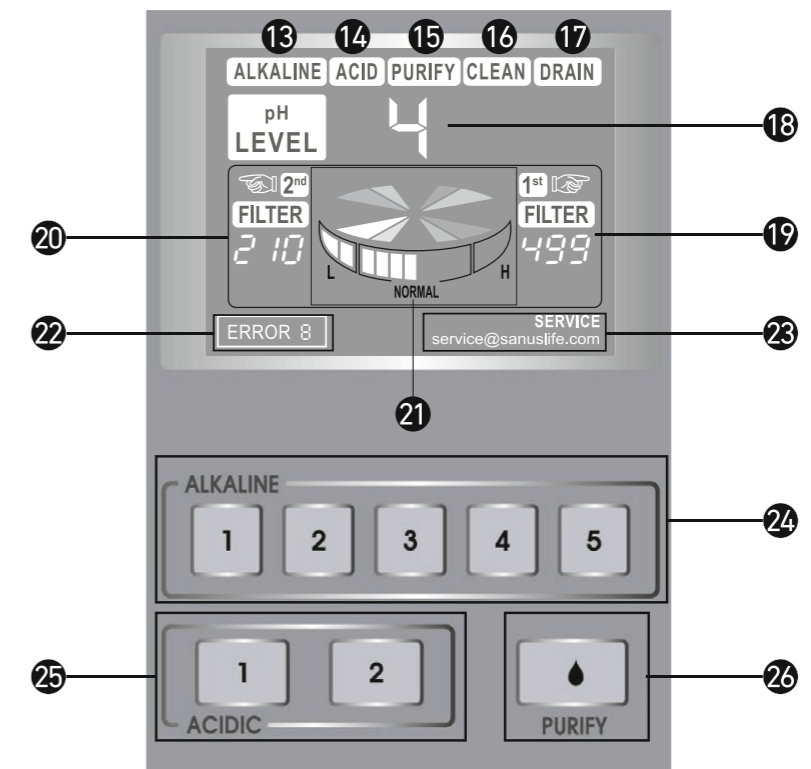

- | | | |
|----|----------------------------|---|
| 13 | Alkaline water | Lights up when an alkaline level (ALKALINE) is selected. |
| 14 | Acidic water | Lights up when an acidic level (ACID) is selected. |
| 15 | Filtered water | Lights up when the PURIFY level is selected. |
| 16 | Clean | Lights up when the unit performs automatic self-cleaning after it is turned off. |
| 17 | Drain | Lights up when the unit is turned on again after cleaning is complete. |
| 18 | Ionization level | Displays the selected ionization power program. |
| 19 | Filter indicator (Right) | Indicates when filter #1 has reached the maximum filter capacity. |
| 20 | Filter indicator (Left) | Indicates when filter #2 has reached the maximum filter capacity. |
| 21 | Flow rate display | Indicates the flow rate. The displayed bars should always be in the „normal“ range. |
| 22 | Error message | Displayed in case of a malfunction. |
| 23 | Service contact | Shows the e-mail address for customer service in Europe: service@sanuslife.com |
| 24 | Alkaline levels (ALKALINE) | Selection of the ionization power of the alkaline water; alkaline water flows out of the upper outlet (1 = weak, 5 = strong). |
| 25 | Acidity levels (ACID) | Selection of the ionization power of the acidic water; acidic water flows out of the upper outlet (1 = weak, 2 = strong). |
| 26 | PURIFY | Filtered water flows out of the upper and lower outlets; ionization is deactivated. |

1 Installation (water inlet connector and device configuration)

It is highly recommended for a specialist to carry out the connection to a water supply. We recommend you to contact the plumber of your choice.

1.1 Using the quick release fastener

The connection parts of the ECAIA ionizer S have quick release fasteners to simplify the installation of the water pipes. The procedure below describes how these quick release fasteners operate.

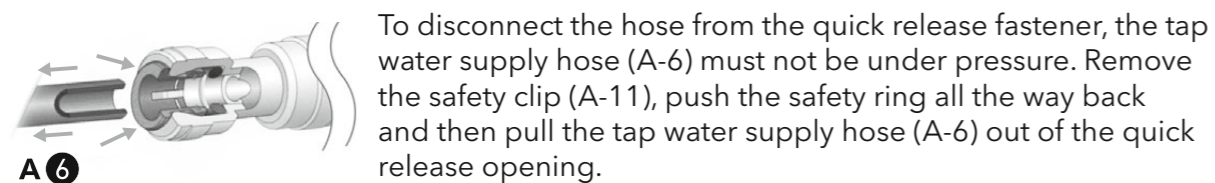
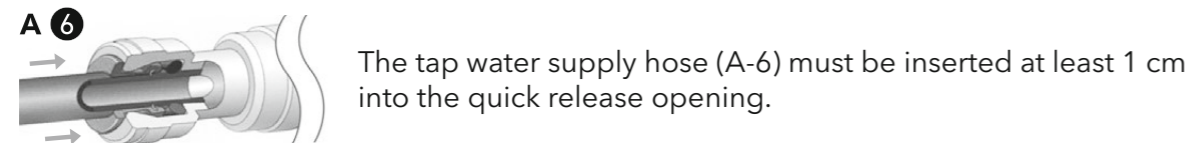
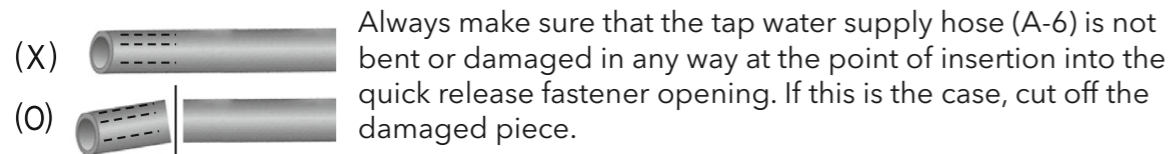

1.2 Sieve for tap water supply hose

A small sieve (A-7) is included with a device, which prevents coarse particles in the tap water from entering the device.

To mount the sieve (A-7), simply cut the tap water supply hose (A-6) in half and connect the two ends to the quick release fastener opening on the sieve (A-7). Please pay attention to the direction of the flow (arrow shown on the sieve); the arrow must point in the direction of the water flow. Finally, firmly secure the 2 safety clips 1/4" (A-11).

The ideal position for the sieve is immediately following the diverter valve (A-9) or the T-piece (A-10).

Note: If the water flow becomes slower, check the sieve (A-7) and clean it. If it is very dirty, it must be replaced.

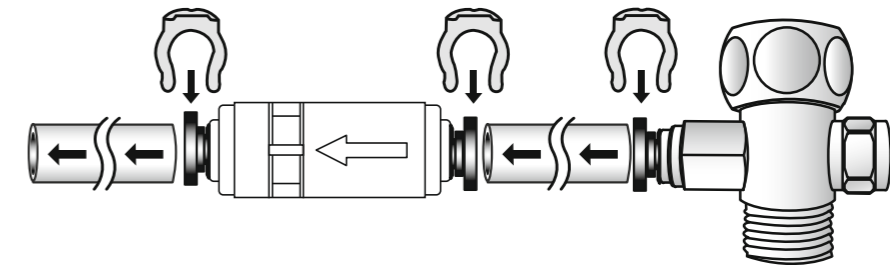

1.3 Temporary connection to the water tap

The ECAIA ionizer S can be connected to any water tap using the diverter valve (A-9), provided that the water tap has a compatible standard thread (internal thread M24, external thread M22).

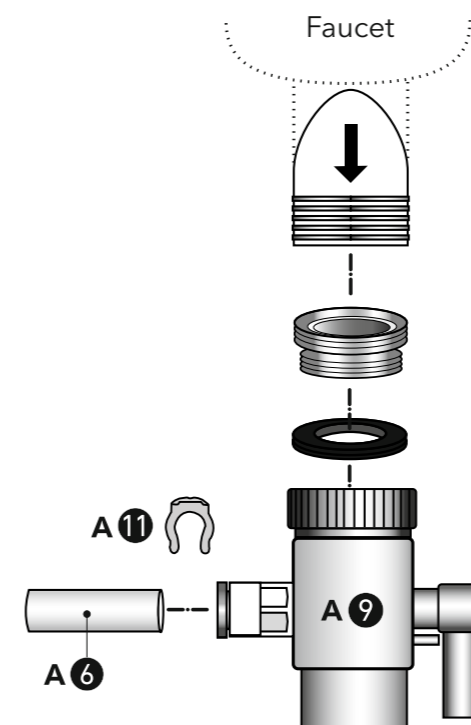

1. Remove the aerator from the faucet and replace it with the diverter valve (A-9). The intermediate thread is used depending on the type of a thread (internal or external thread).
2. Connect the tap water supply hose (A-6) to the quick release fastener opening on the diverter valve (A-9) and fix the safety clip 1/4" (A-11).

3. Connect the other end of the tap water supply hose (A-6) to the quick release fastener opening of the water inlet (B-11) on the bottom of the ECAIA ionizer S and fix the safety clip 1/4" (A-11).

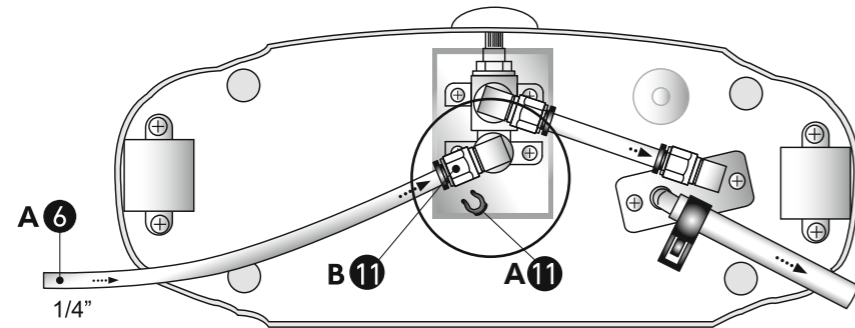

4. The water pressure can be adjusted with the water flow rate regulator (B-3) on the device.

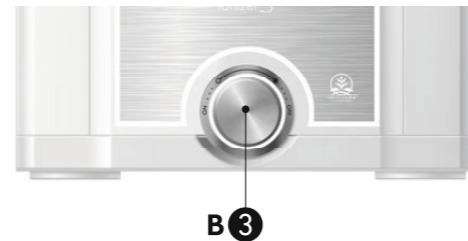

Note: The ECAIA ionizer S is only suitable for cold drinking water! The flow of warm or hot water into the device can damage the filters and various seals.

IMPORTANT: If electric water heater is installed to depressurize through the faucet, the connection should not be carried out using an adapter. This may cause damage to the water heater.

1.4 Permanent connection to the angle valve (appliance in above-counter position)

The ECAIA ionizer S can also be attached to the angle valve (3/8") under the sink. If the device is placed above the working surface, the tap water supply hose (A-6) must go through a hole made in the working surface or sink with a diameter of at least 6 mm.

1. Install the T-piece (A-10) on the angle valve of the cold water pipe. If necessary, the cold water supply pipe to the faucet must be disconnected and connected with the T-piece in between.

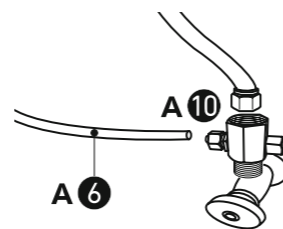

CAUTION: When assembling please make sure the connection pins on the T-piece do not bend sideways. This may cause a micro crack, which can even lead to breakage due to the constant water pressure.

2. Connect the tap water supply hose (A-6) to the quick release fastener opening on the T-piece (A-10) and fix the safety clip 1/4" (A-11).

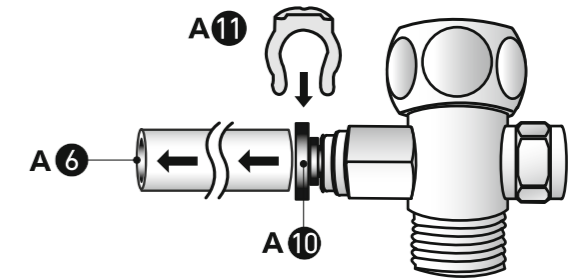

3. Pass the tap water supply hose (A-6) through an opening in the counter or sink (diameter at least 6 mm) to the position where you have placed the ECAIA ionizer S.

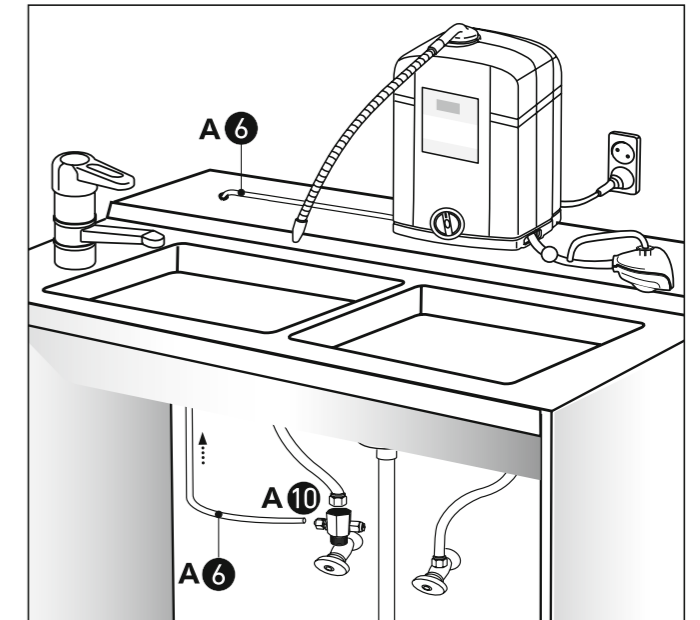

4. Connect the other end of the tap water supply hose (A-6) to the quick release fastener opening of the water inlet (B-11) on the bottom of the ECAIA ionizer S and fix the safety clip 1/4" (A-11).

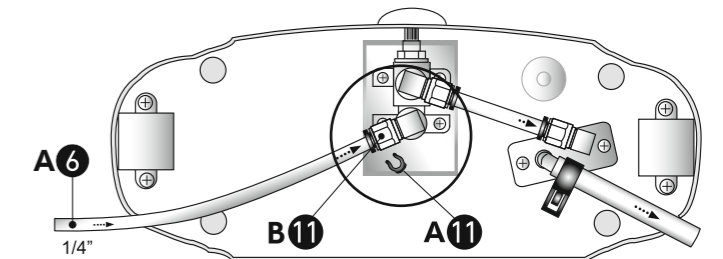

5. The water pressure can be adjusted with the adjustment screw on the T-piece (A-10).

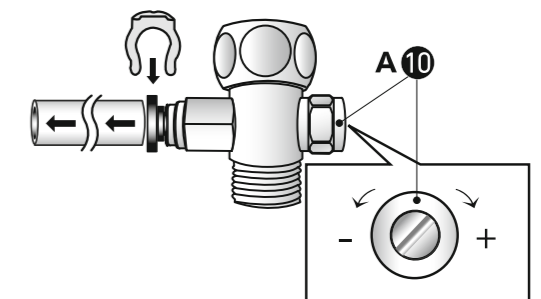

1.5 Permanent connection to the angle valve (ECAIA ionizer S+; appliance in below-counter position; using the additional ECAIA ionizer S faucet)

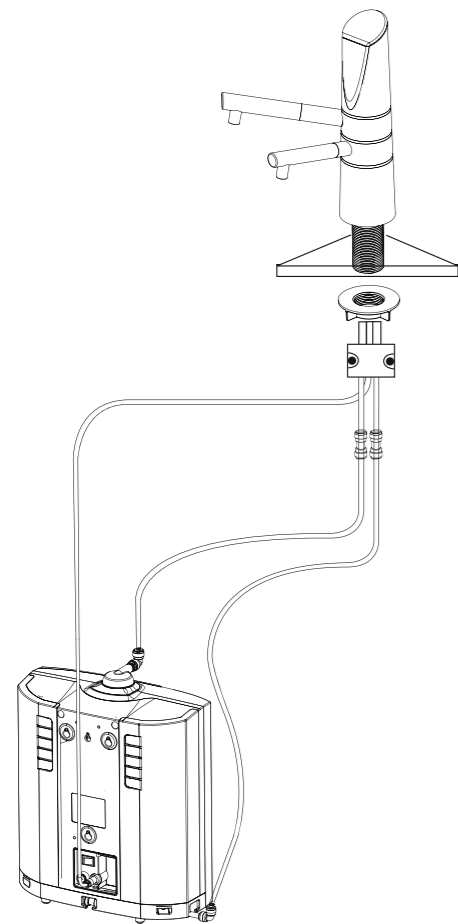

The ECAIA ionizer S+ can be permanently connected to the angle valve under the sink, as described under point "1.4 - Permanent connection to the angle valve (appliance in above-counter position)". Due to the positioning of the device under the sink, it must be operated using the special ECAIA ionizer S faucet. A solenoid valve must also be interconnected to control the water supply.

To install the ECAIA ionizer S faucet, use the user manual included with the faucet.

Note: A solenoid valve is to be used, if the ECAIA ionizer S is reprogrammed to ECAIA ionizer S+. Therefore, it is not possible to receive filtered water in the event of a power shortage.

1.6 ECAIA ionizer S wall mounting

The ECAIA ionizer S can be placed standing or mounted to the wall. Wall mounting is very easy and the ECAIA ionizer S can thus be positioned in any kitchen, next to or behind the sink, to save space.

1. Attach the supplied installation diagram (A-12) to the wall where you want to position the device.
2. Choose the vertical or horizontal mounting method and drill 2 holes accordingly.
3. Insert the supplied dowels (A-12) and secure the screws (A-12) into the wall.
4. Hang the ECAIA ionizer S on the screws you just attached.

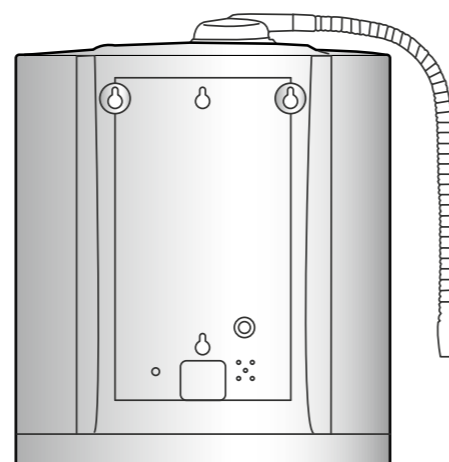

1.7 Assembly of the alkaline outlet hose and the acidic water tap

For reasons of hygiene, it is recommended to use the supplied acidic water tap (A-3) with the ECAIA ionizer S (not necessary with the ECAIA ionizer S+).

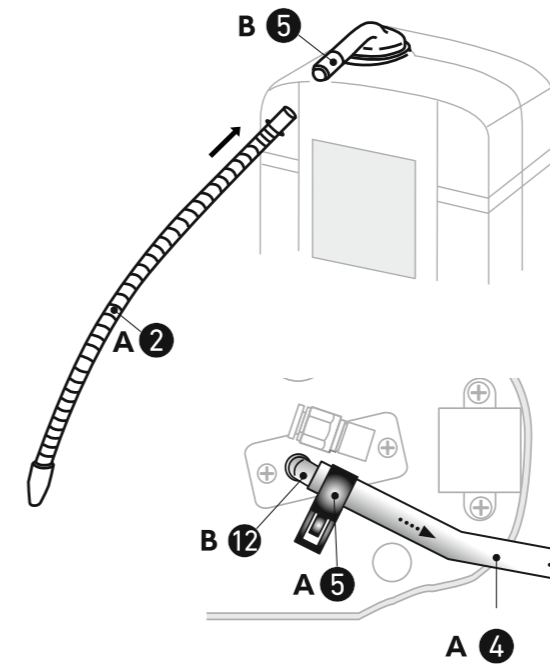

1. Screw the alkaline outlet hose (A-2) to the upper water outlet (B-5).

2. Plastic hose for acidic water 7/9 mm (A-4) should be attached to the lower water outlet (B-12) of the device. If necessary, the tube can be secured with the supplied tube clamp (A-5). Since no water pressure is exerted on this tube, this step is optional.

3. Using the attached double-sided adhesive tape, secure the magnetic button of the acidic water tap (A-3) to the working surface or to the sink so that the stainless steel spout from the acidic water tap (A-3) opens into the sink. Afterwards cut the plastic hose for acidic water 7/9 mm (A-4) to the required length and attach the end to the acidic water tap (A-3). The plastic hose for acidic water 7/9 mm (A-4) should not be higher than the position of the water flow rate regulator (B-3). Too long, bent or positioned higher tube may affect the ionization or the taste of the water.

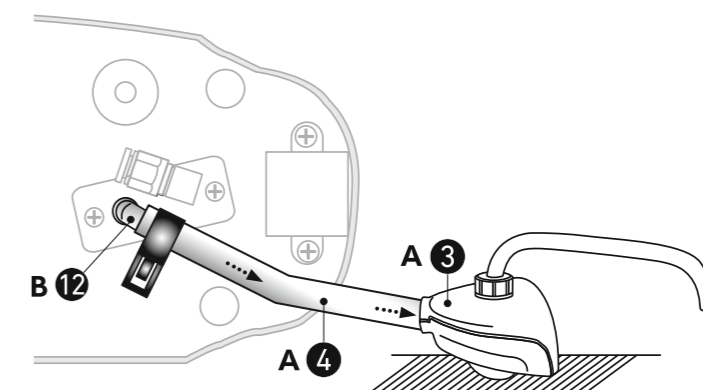

Note: Make sure that the alkaline outlet hose (A-2) or the stainless steel spout from the acidic water tap (A-3) do not come into contact with dirty objects. Likewise, the plastic hose for acidic water 7/9 mm (A-4) should not be connected directly to the drain. This could cause re-contamination of the device.

1.8 Before use

Before you can use the ECAIA ionizer S, you must carry out the following steps:

1. Plug the power cable of the ECAIA Ionizer S into the socket. The device requires 230V (US model 120V).
2. Turn on the water and wait until the filters and the device are full. The device switches on automatically as soon as water flows through the device.

Note: The ECAIA ionizer S is only suitable for cold drinking water!

When the filters are new, the water may initially come out dark due to the activated carbon particles. Let the water run until it clears out. If necessary, switch the device on and off several times so that all suspended solids are rinsed out.

1.9 Language settings

The ECAIA ionizer S has a guide speech which informs the user about different settings. You can choose between 4 different languages. English (LA0 default), German (LA1), Italian (LA2), or Spanish (LA3).

If you want to change the language, proceed as follows:

1. With the device switched off, press the "PURIFY" button and hold it down for at least 3 seconds. The display switches on and "LA0" appears.

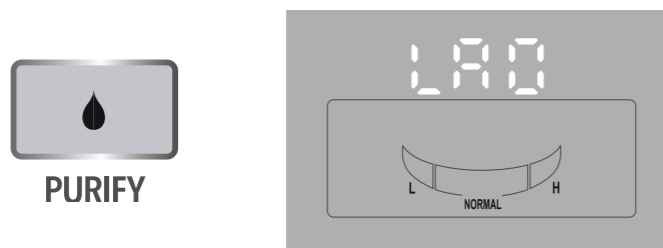

2. You can select the desired language by pressing the "PURIFY" button again:

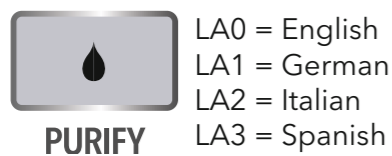

3. After you have selected the language, wait at least 3 seconds until the display switches off again and the selected language is automatically saved.

1.10 Volume configuration

There are 2 ways to adjust the volume. Either via the volume control (B-10) or via the submenu.

Note: Unfortunately, only setting option B is available for the models of the first production series.

A Configuration via the volume control

Using a small Phillips head screwdriver, you can turn the small volume control screw (B-10) on the back of the device and thus adjust the volume of the guide speech.

B Configuration via the submenu

The volume can be adjusted in 3 levels via the submenu or switched off completely.

To configure via the submenu, proceed as follows:

1. Switch off the device and simultaneously press buttons of alkaline levels 1 and 2 denoted "ALKALINE" and hold them down for at least 3 seconds. Afterwards the display turns on.



2. Press button of alkaline level 1 denoted "ALKALINE" until "U.3 9d" appears on the display.

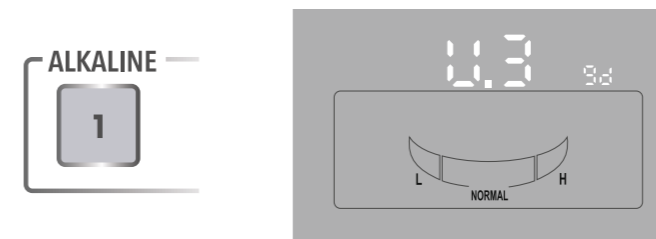

3. By pressing button acidic level 1 denoted "ACIDIC" you can select the desired volume:



4. When you have selected the desired volume, press buttons of alkaline level 1 and 2 denoted "ALKALINE" again at the same time and hold them until the display switches off. This saves the setting.



Note: Please make sure you do not make any other adjustments in the submenu. There is a risk of changing other parameters and thus impairing the function of the device!

1.11 Flow rate configuration

Depending on how the device was connected, there are 2 different ways to regulate the water pressure and thus the flow rate. The water pressure should always remain unchanged to guarantee a constant ionization performance. The general rule is: The slower the flow rate, the stronger the ionization performance.

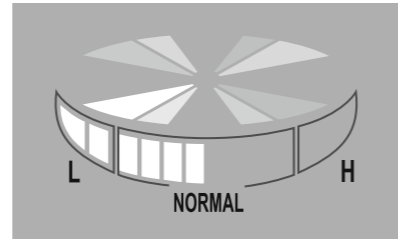

- Connection to the faucet according to description 1.3:
If the device is connected to the water tap using the diverter valve (A-9), the water flow rate regulator (B-3) on the device is used to adjust the water pressure. Completely open the cold water faucet and position the switch-over lever of the diverter valve (A-9) so that the water flows into the ECAIA ionizer S. Afterwards turn the water flow rate regulator (B-3) on the device slowly clockwise towards OFF until the bars on the flow rate display (B-21) are in the "normal" range. Once the flow is set, you can turn the device on or off simply by turning on or off the water tap. If the water supply is interrupted, the device switches off automatically.

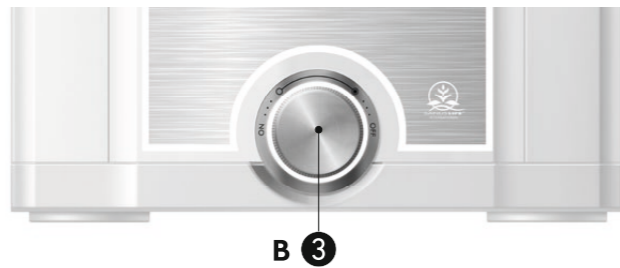

- Connection to the angle valve according to description 1.4 and 1.5:
If the device is connected directly to the angle valve using the T-piece (A-10), the pressure can be regulated at the T-piece (A-10). Turn the water flow rate regulator (B-3) on the device counter-clockwise towards ON until it stops. Thereafter regulate the water pressure on the T-piece (A-10) by opening or closing the small screw on the opposite side of the quick release opening until the bars on the flow rate display (B-21) are in the "normal" range. The device can be switched on or off by turning the water flow rate regulator (B-3) on the device. If the water supply is interrupted, the device switches off automatically.

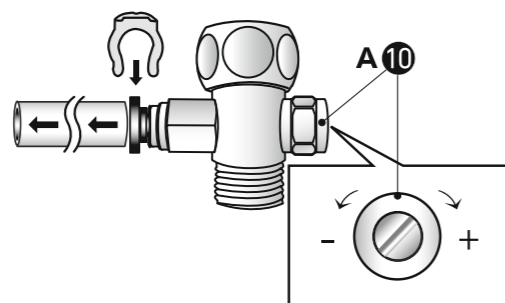

Note: If the water pressure is too high, the message "Error 4" or "Error F" appears on the display (B-22). If the water pressure is too low, the device switches off automatically.

1.12 Description of the buttons

The ECAIA ionizer S has a total of 8 buttons to produce water with different properties.

1. Alkaline water (B-24), buttons of alkaline levels 1 to 5 (ALKALINE) - alkaline water flows out of the upper water outlet (B-5), 1 = slightly alkaline, 5 = strongly alkaline.

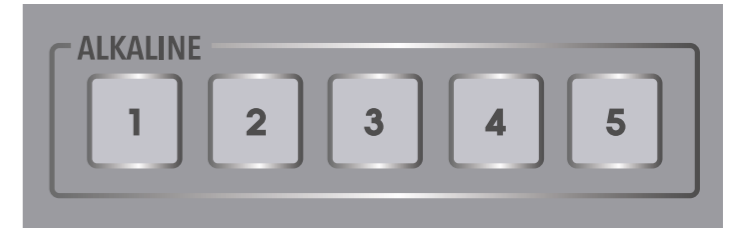

2. Acidic water (B-25), buttons of acidic levels 1 to 2 (ACID) - acidic water flows out of the upper water outlet (B-5), 1 = slightly acidic, 2 = strongly acidic.



Note: Since the selection of the alkaline levels 1 to 5 (B-24) produces alkaline water at the upper water outlet (B-5) and acidic water at the lower water outlet (B-12) or at the acidic water tap (A-3), the buttons for acidic water (B-25) are generally rarely used.

3. Filtered water (B-26), button of the level PURIFY - filtered water flows out of the upper water outlet (B-5) and lower water outlet (B-12), ionization is deactivated.



These framed buttons have a memory function. So if you select one of these ionization level buttons and then switch off the device, this setting remains saved.

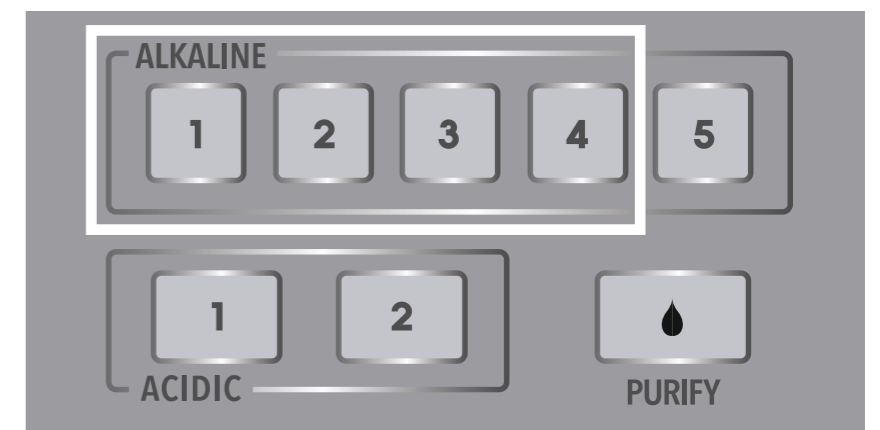

Example: You select the alkaline level 3 and then switch off the device. The next time you switch on the device, alkaline level 3 is automatically selected again.

These framed buttons have NO memory function. If you selected one of these buttons when switching off the device, the next time you start the device, the last selected level, which has a memory function, will be selected.

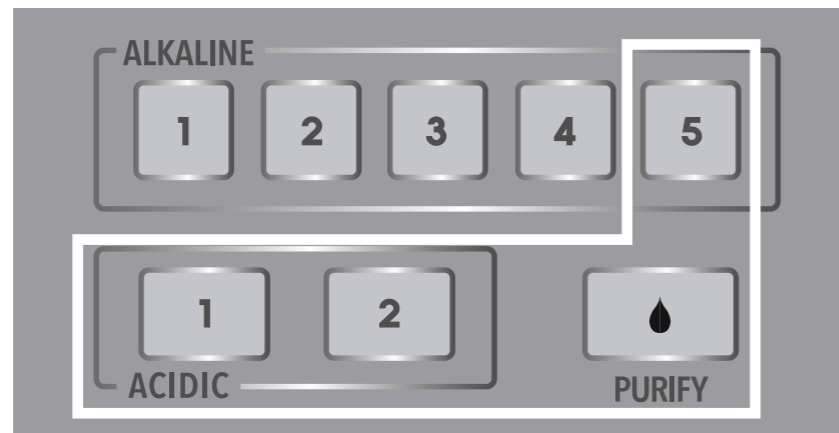

Example: When you switch on the device the alkaline level 4 is set. Select the alkaline level 5 and switch off the device. The next time the device is switched on, the alkaline level 4 is automatically selected again as the alkaline level 5 can not be saved.

1.13 Control of the ionization performance

The ionization performance depends on the water used and can therefore vary greatly from place to place. It is therefore very important to control the ionization performance.

Tip: Check the ionization performance regularly, as changing the filter or calcification of the electrolysis chamber can also affect the ionization performance. If the device is new or new filters have been installed, the measurement should be carried out again after 2-3 days, as new filters can influence the measured values.

You can control the ionization performance by measuring the pH value. Use the pH testing liquid provided with the pH level color chart (A-8).

Important: Changing the flow rate also changes the ionization performance. Please make sure that the flow rate always remains the same, i.e. that the same number of bars always light up on the flow rate display (B-21) to indicate the "normal" range. The general rule is: The slower the flow rate, the stronger the ionization performance.

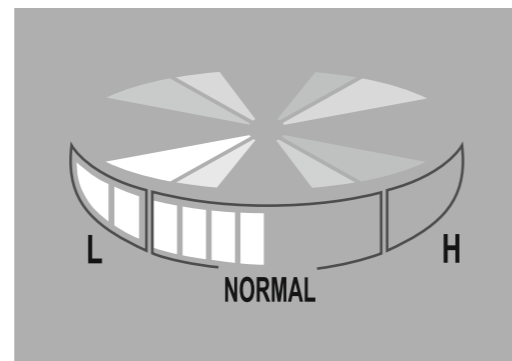

The ECAIA ionizer S has 5 levels of alkaline water (B-24), 2 levels of acidic water (B-25) and one level of filtered water (B-26). Please check the ionization performance using the 5 alkaline levels (B-24).

To measure the ionization performance, switch on the device and select the alkaline level 1. Let the water run for about 30 seconds, then take a water sample and add a few drops of pH testing liquid (A-8). Depending on the water color, you can use the pH level color chart (A-8) to identify the corresponding pH value for this level. Then select the alkaline level 2, let the water run for about 30 seconds and repeat the pH value measurement. Continue these measurements up to alkaline level 5. Ideally, the water should turn purple in the area of alkaline levels 3 or 4 (pH 9 to 9.5).

Tip: The less the amount of test water is, the less pH testing liquid you need. 5 to 10 milliliters of test water are sufficient to determine the pH value. Only 1-2 drops of pH testing liquid is required for this.



Warning label for pH testing liquid (A-8):

- Do not drink the pH testing liquid. If the pH testing liquid is accidentally consumed, immediately drink plenty of water.
- Avoid eye contact. If the pH testing liquid comes into contact with the eyes, wash them out immediately with plenty of water and consult a doctor.
- Do not store pH testing liquid near fire or a source of heat.
- Keep pH testing liquid out of the reach of children.
- Store pH testing liquid in a cool, dark place. Avoid high temperatures and excess humidity.
- Cap the vial after each use. Do not spill any pH testing liquid; resulting stains are difficult to remove. If the pH testing liquid gets on surfaces, wipe up immediately with plenty of water.

1.14 Setting ionization performance

The ECAIA ionizer S has a total of 28 alkaline and acidic levels, which can be controlled by configuring the ionization performance via the submenu.

The respective 5 alkaline and 2 acidic levels can be set to low or high level again using 4 levels in the submenu. The device is configured to submenu level 3 at the factory.

If a purple color (pH 9 to 9.5) after a period of use of 2-3 days with the alkaline levels 3 or 4 is not achieved, the ionization performance can be set higher. If, on the other hand, a purple color (pH 9 to 9.5) is already in the alkaline level 1 or 2, the ionization performance can be set lower.

How to set the ionization performance:

1. Turn on the device so that water flows out.
2. Select the alkaline level 1 and hold this button down for at least 5 seconds until the display switches over. You will read "13" on the display. The first number (1) stands for the respective level (in this case for "alkaline level 1"), the second number (3) stands for the ionization performance in the submenu. You can choose between 1 and 4, where 1 corresponds to the lowest and 4 to the highest ionization performance.

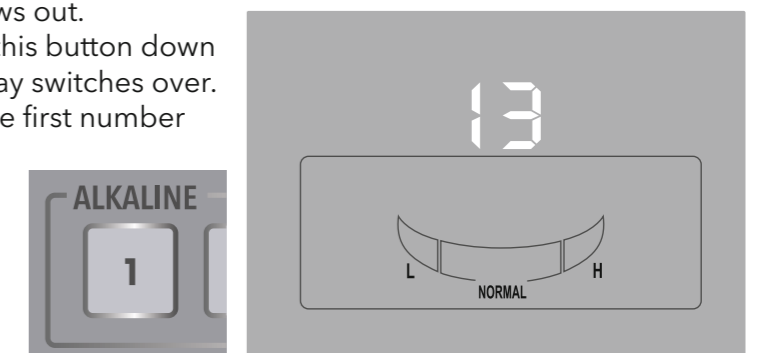

3. By pressing the “alkaline level 1” button again, you can switch through the individual levels of ionization performance. If you want to set the ionization performance to a higher level, press the “alkaline level 1” button until “14” appears on the display. If you want to set the ionization performance to a lower level, “11” or “12” should appear on the display.

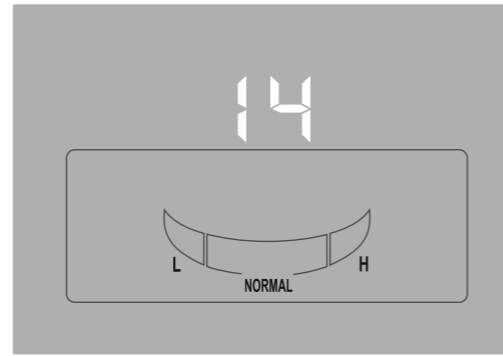

4. Save the setting by pressing the “PURIFY” button. The display will show the alkaline level 1 again.

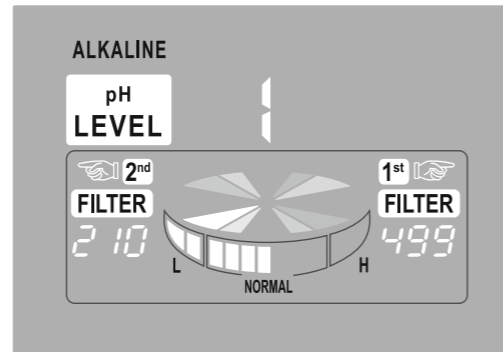

5. Repeat the settings from points 1 to 4 for all other levels (alkaline level 2 to 5 (B-24) and acidic level 1 to 2 (B-25)).

Important: Make sure that the same ionization performance is set in the submenu for each level (alkaline level 1 to 5 and acidic level 1 to 2). For instance, if you have set the ionization performance to 4 for “alkaline level 1” (display submenu = 14), then all other levels must also be set to ionization performance 4.

- Example:
- alkaline 1 = 14
 - alkaline 2 = 24
 - alkaline 3 = 34
 - alkaline 4 = 44
 - alkaline 5 = 54
 - acidic 1 = 64
 - acidic 2 = 74

The ionization performance can also be regulated by changing the flow rate. The faster the flow rate, the less ionized is the water. If the bars on the display (B-21) are in the lower “normal” range, the flow rate is slower and thus the ionization performance is stronger than when the bars are in the upper “normal” range, with the water flowing faster through the electrolysis unit. Depending on the water quality, it is possible that a pH value of 9 (purple coloring) can only be achieved with setting the alkaline level to 5, with very slow flow rate (bars in the lower “normal” range) and with the highest ionization performance (display submenu = 54).

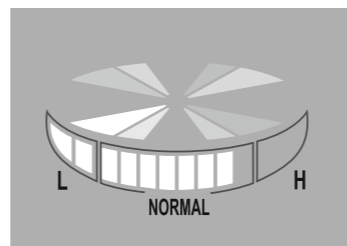
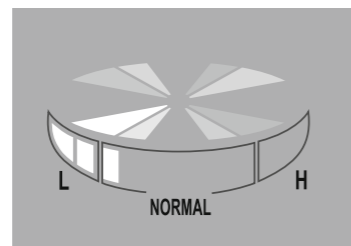

Note: Make sure that water always comes out of the lower water outlet (B-12) (acidic water tap (A-3)). Otherwise, proper ionization cannot be guaranteed.

Configuration via the additional ECAIA ionizer S faucet:

The above settings can also be configured using the control buttons of the ECAIA ionizer S faucet. To set the alkaline levels, press the ALK button (D2); for the acidic levels, press the ACID button (D3). To save the setting, press the PU button (D4).



If you have any further questions regarding the configurations, please contact the Support Team of SANUSLIFE INTERNATIONAL. You can find the contact details on the website www.sanusproducts.com.

1.15 Lower water outlet (B-12) configuration

The amount of water at the lower water outlet (B-12) can be regulated using a rotating metal sleeve. We recommend that you keep the factory default settings.

The outlet opening is set in the factory settings so that the ratio of alkaline to acidic water is approximately 6 to 4.

The flow rate at the lower water outlet (B-12) can be changed by turning the metal sleeve. This also affects the ionization performance. The less water flows out of the lower water outlet (B-12), the weaker the ionization performance.

Note: The metal sleeve has an opening on one side and can be rotated 360°. If the opening is at the top (horizontal notches), the lower water outlet (B-12) is completely open. If the metal sleeve is rotated 180°, the lower water outlet (B-12) is completely closed. Correct ionization is no longer guaranteed. This can negatively affect the quality and taste of the water. Under certain circumstances, this setting can even damage the device.

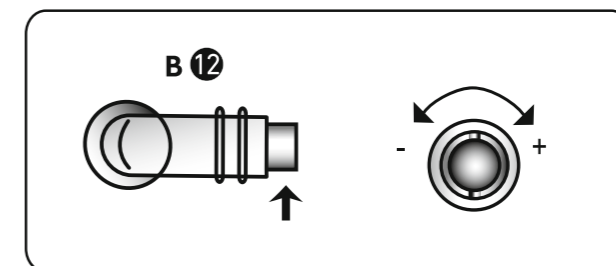

2 ECAIA water production

Different types of water and their subsequent production with the help of the ECAIA ionizer S is described as follows.

In principle, you should always consume the water that flows out of the upper water outlet (B-5).

2.1 Alkaline ionized water

The alkaline ionized water is usually the most recommended for drinking and cooking. The level of the pH value can be set individually with the buttons for the alkaline levels (B-24). For the setting, see point "1.13 - Control of the ionization performance".



If the device is set to one of the 5 alkaline levels, alkaline water flows out of the upper water outlet (B-5). Contrary, acidic water flows out of the lower water outlet (B-12).

The display (B-18) shows the respective alkaline ionization level (1 to 5) and the message "ALKALINE" (B-13).

For long-term consumption, water with pH of 8.5 to 9.5 is generally recommended. This pH value is reached as soon as the water turns purple by using the pH testing liquid (A-8).

Example: If your measurements with the help of the pH testing liquid (A-8) show blue color at level 2 and a purple color at level 3, then you can drink the water at level 3 long term. If your measurements show blue color at level 3 and a purple color at level 4, then you can drink water at level 4 long term.

Recommendation: If you have never drunk ECAIA water before, we advise you to drink only slightly ionized water for the first few weeks and then slowly increase the pH value. Since ECAIA water can have high solvent properties, there is a possibility that detoxification symptoms may occur after ingestion. This can manifest itself as headache, nausea, digestive problems or other symptoms.

Note: If the ECAIA water has a strange, fishy taste, the pH is too high. Reduce the ionization performance by selecting a lower level or slightly increasing the flow rate. If necessary, set the ionization performance - as described under point "1.14 - Setting ionization performance".

Important: Alkaline ionized water can increase the absorption of various substances in the body. In order to avoid a possible overdose, it is recommended to AVOID taking medication with alkaline ionized water (ALKALINE 1-5) (B-24), and take medicine with filtered water (PURIFY) (B-26) only. If you have health problems, please contact if necessary, your trusted doctor.

2.2 Acidic ionized water

The acidic ionized water is produced using the acidic level buttons (B-25), but is rarely selected as a rule. The acidic water always runs out of the lower water outlet (B-12), when alkaline ionized water is produced.

If the device is set to acidic level 1 or 2 (B-25), acidic water flows out of the upper water outlet (B-5). Contrary, alkaline water runs out of the lower water outlet (B-12). In this case, a quasi reverse function takes place. The water flow is reversed.

The display (B-18) shows the respective acidic ionization level (1 to 2) and the message "ACID" (B-14).

This setting produces simultaneously a melody indicating that no drinking water is flowing out of the upper water outlet (B-5).

You can also measure the different pH values between acidic levels 1 and 2 (B-25) with the pH testing liquid (A-8).

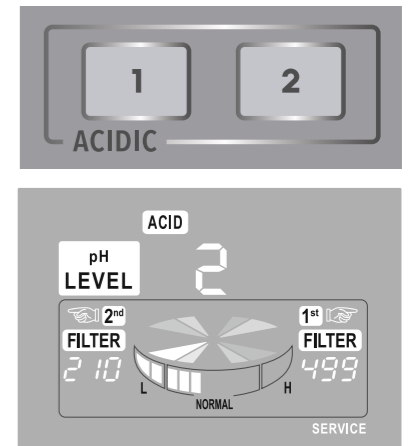

2.3 Filtered water only

If the "PURIFY" level (B-26) is selected, the ionization is deactivated and filtered, non-ionized water flows both out of the upper water outlet (B-5) and the lower water outlet (B-12).

The display (B-18) shows the letter "P" and the message "PURIFY" (B-15).

This only filtered non-ionized water is, as already mentioned, suitable for taking medication.

Note: In the event of a power shortage or the display switched off, only filtered water comes out of the device. The treatment process is the same as when selecting the "PURIFY" level (B-26). Since the ECAIA ionizer S has no solenoid valves, filtered water can also be produced in the event of a power shortage (this does not apply to the ECAIA ionizer S+ variant, where a solenoid valve is used to control operation via the additional "ECAIA ionizer S faucet").

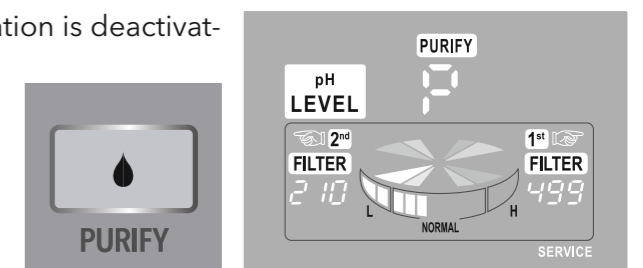

2.4 Proper use of ECAIA water

Ionization level *	Use	Ideal pH value		
ALKALINE	5	Washing vegetables and fruits	9.0 - 9.5	▲ Alkaline
	4	Drinking and cooking	8.5 - 9.0	
	3	Drinking and cooking	8.0 - 8.5	
	2	Drinking	7.5 - 8.0	Neutral
	1	Drinking may be started Baby food preparation	7.0 - 7.5	
ACID	1	Watering flowers	5.5 - 6.5	Acidic ▼
	2	Cleaning, washing dishes and washing hair	3.5 - 4.5	

* Depending on the water quality and the setting of the device, the pH value of the individual ionization levels can vary.

Note: Since being ionized, alkaline water does not remain stable, it loses its properties after a while. We recommend therefore to consume freshly prepared ECAIA water.

Recommendation: Never store ECAIA water in copper, aluminum or plastic (PET) bottles! If you want to fill up ECAIA water for transport, a glass bottle is the best option. SANUSLIFE INTERNATIONAL recommends using the MY WATER BOTTLE, available at the SANUSSTORE.

Other tips

- ECAIA water with a pH value of 8.5 - 9.5 is suitable for long-term consumption.
- If you have alkalosis, follow your general practitioner's instructions.
- Take medication with neutral water ("PURIFY" B-26).
- To begin with, drink only small amounts of lightly ionized ECAIA water with a pH value between 7.0 - 8.0 and increase the amount and pH value slowly.
- Drink ECAIA water with caution if you have kidney problems or problems with your calcium balance.
- Check the pH value of the ECAIA water regularly with the included pH testing liquid (A-8).
- When you switch on the device, always let some water run out first.
- When the ECAIA water is heated, the positive properties are lost.
- Only use the ECAIA ionizer S with water that complies with the drinking water quality requirements.
- Ionized, alkaline water should not be used to breed fish or other aquarium animals.

3 Filter and filter replacement

The ECAIA ionizer S has the double "filter technology by SANUSLIFE INTERNATIONAL". This ensures the reduction of numerous harmful substances.

Filter No. 1 has a sediment insert to remove large structured particles and a special activated carbon mixture to remove mainly heavy metals from the water.

Filter No. 2, on the other hand, has a special activated carbon mixture to remove fine pollutants and a microfiltration fiber membrane to hold back any germs and bacteria. The filters must be replaced regularly to ensure optimal filter output.

Note: The ECAIA ionizer S is a device for treating drinking water. Only use water that complies with the drinking water ordinance.

3.1 Filter shelf-life

The filters have an unlimited shelf life as long as they are not exposed to water or moisture.

The filters' shelf-life depends on 2 factors: The flow rate and the time of it's first use.

Filter No. 1 has a maximum flow capacity of 1,800 liters of water. This flow rate is reached as soon as the number 999 appears on the display for filter No. 1 (B-19) and the filter replacement is indicated.

Filter No. 2 has a maximum flow capacity of 3,600 liters of water. This flow rate is reached as soon as the number 999 appears on the display for filter No. 2 (B-20) and the filter replacement is indicated.

Both filter No. 1 and filter No. 2 require replacement a maximum of 6 months after the first use, regardless of whether the maximum flow rate is reached and the filter replacement is signaled by the device or not. The device does not register the first usage of the filter. For this reason, we recommend that you always use a waterproof pen to write the date in the designated space provided on the filter label when you insert the filter. This way you can always monitor the best-before date of the filter (= 6 months after contact with water) and when the filter needs to be replaced.

Note: If the filter is not changed, even though the maximum flow rate has been reached, the device will not switch on immediately. The display will not switch on until a new filter has been inserted, regardless of the water flow.

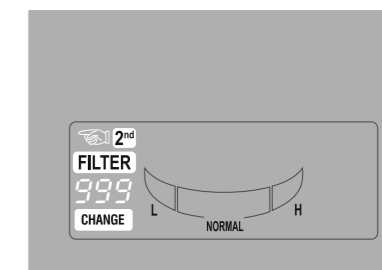
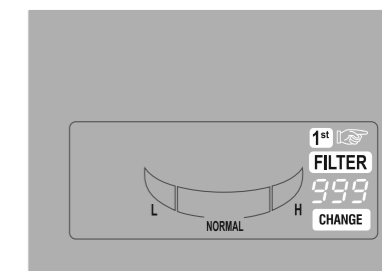

Recommendation:

If the ECAIA ionizer S is not used for a period of several weeks, we recommend you remove the filters first, seal them airtight in a clean plastic bag and store them in the refrigerator. This can prevent bacterial contamination and impurity.

If the ECAIA ionizer S is not used for a period of more than 2 months, we recommend you clean it as described under point "4.3 Cleaning and disinfection" and replace the filters, even if the best-before date has not yet been reached.

The following circumstances can shorten the shelf-life of the filters:

- Rust particles or suspended solids in the water.
- Old pipelines.
- Increased amounts of heavy metals and pollutants in the water.
- Impure or bacterially contaminated water.
- When hot water flows through the filters.

3.2 Filter replacement

If the filter replacement is indicated on the device, or if a filter has reached the best-before date of 6 months, it must be replaced. Proceed as follows:

1. Remove the filter cover (B-4) by pressing the filter cover lock button on the side of the lower area of the cover and pull the filter cover up.

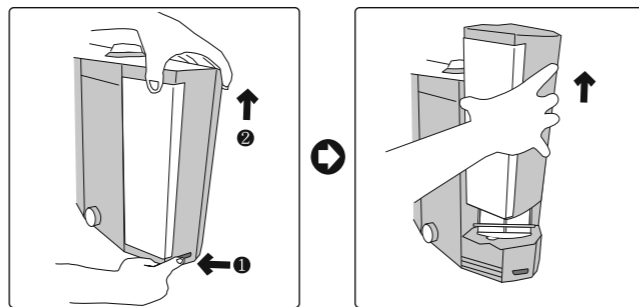

2. Disconnect the plug lock on the filter cable.

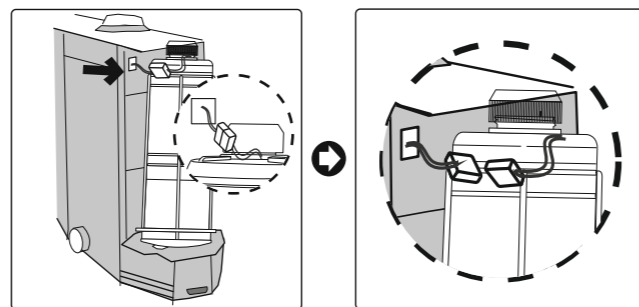

3. Turn the filter counterclockwise and remove it by pulling the filter up and out. The residual water may flow out of the filter or the device. Dry excess water with a clean, absorbent cloth. Excess water can penetrate inside the device.

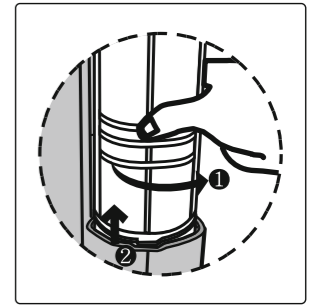

CAUTION: If water runs off inside the device, the device must not be tilted sideways, backwards or forwards. Otherwise electronic components inside can be damaged!

4. Take the new filter out of the packaging and use a waterproof pen to write the date on the designated space provided on the label. This will allow you to always monitor when the filter reaches the best before date of 6 months.

Tip: To ease the filter consequent removal, apply an oily liquid onto the seals, e.g. Vaseline.

5. Simply slide the filter into the provided opening and turn it clockwise until it stops.

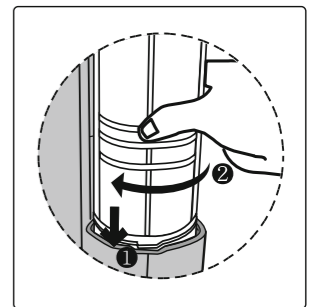

6. Connect the plug lock on the filter cable.

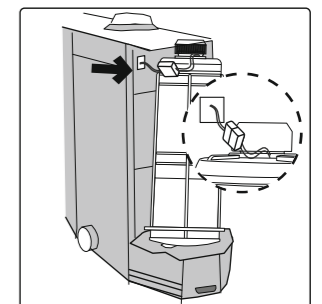

7. Place the filter cover (B-4) in the place provided on the device and slide it down until it clicks into place. If the filter cover does not click into place, release the fixing on the filter cover lock button.

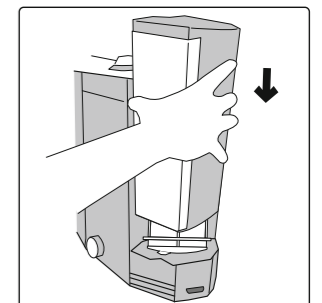

4 Maintenance and care

To enjoy your ECAIA ionizer S for a long time, it is important that you handle, maintain and care for your device carefully and properly. In this context, you should always observe the following:

- The ECAIA ionizer S is suitable for treating drinking water only.
- Only cold water is allowed to flow through the filters.
- Clean and descale your ECAIA ionizer S regularly, depending on the use and condition of the inlet water.
- Avoid contact with dirty objects, e.g. wiping cloths or reusable towels.
- Occasionally use a food-safe disinfectant to prevent contamination. SANUSLIFE INTERNATIONAL recommends the regular use of ECAIA+ allhygienics, which you can use to spray and clean the alkaline and acidic spouts, the filter holder, but also the entire device from the outside.

4.1 Self-cleaning function

The ECAIA ionizer S has an automated pole reversal of the electrodes in the electrolysis unit. Each time it is switched on, the pole and the outflow are reversed mechanically. This prevents excessive calcification of the electrodes and thus ensures better ionization performance, especially with hard water.

The self-cleaning function by means of pole reversal replaces the previous self-cleaning function, which is still integrated in the models of the first production series of the ECAIA ionizer S. The self-cleaning function described below is no longer available on devices of future series.

When necessary, self-cleaning starts as soon as the device is switched off or the water supply is interrupted. In this case the message "CLEAN" (B-16) appears on the display and a melody is played. After approx. 30 seconds, the display and the melody automatically switch off.

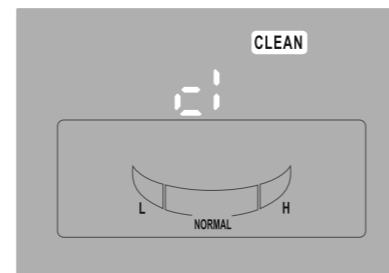

Once the device is switched on the next time, the 2nd step of self-cleaning begins. The message "DRAIN" (B-17) appears on the display and a melody is played again. When approx. 0.2 liters of water runs out (this water is not suitable for drinking), the melody stops. The "DRAIN" display switches off and the display (B-18) shows the last ionization level used. The water is suitable for normal use again.

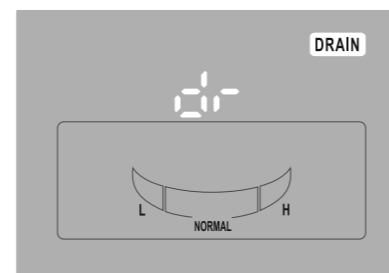

Note: Self-cleaning must not be interrupted prematurely by switching the device on or off. If so, the error message "Error 7" appears.

4.2 Descaling

In order for the ECAIA ionizer S to perform at its best, it is necessary that the device is regularly descaled.

Note: Insufficient descaling can lead to overheating of the electrolysis unit and cause electronic damage which is not covered by the warranty.

The descaling interval depends on several factors, e.g. the intensity of use and the hardness of the water.

Limescale deposits on the upper water outlet (B-5) are a clear indication that a device needs to be descaled. To do this, unscrew the alkaline water flexible discharge hose (A-2). Descaling is required if limescale deposits have formed on the threaded attachment and inside the alkaline water flexible discharge hose (A-2).

The following table provides descaling recommendations depending on the hardness of the water. You can obtain information about the hardness of the drinking water from your drinking water supply company (municipality, city administration).

German hardness Degree (dH)	French hardness Degree (fH)	Degree of hardness	Descaling recommendation
1 - 4	1 - 10	soft	Every 6 months
5 - 8	11 - 20	medium	Every 3 months
9 - 14	21 - 30	hard	Every 4 weeks
15 - 30	30 - 40	very hard	Every 2 weeks
30+	40+		Every 7 days

The specified descaling recommendation depends on the usage of the device! It is based on a daily flow rate of 8 liters (acidic and alkaline water).

Note: Use natural, food-safe citric acid (E330) for the descaling process. Other descaling solutions such as vinegar are not recommended as they can make various seals brittle.

To perform descaling, use the descaling set, consisting of the descaling pump and the associated tube. This is provided free of charge together with the ECAIA ionizer S.

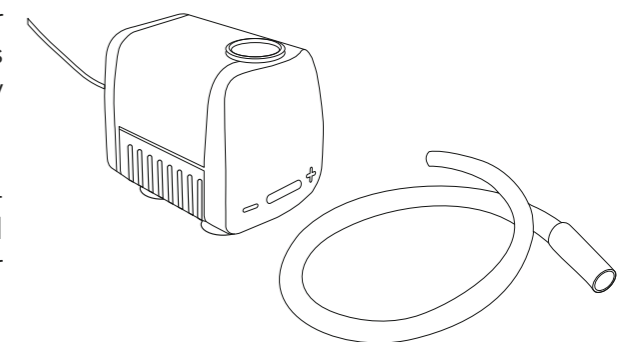

Proceed as follows to descale:

1. Disconnect the power supply by pulling the plug from the socket.
2. Remove the left filter No. 2 as described under point "3.2 - Filter replacement".

CAUTION: If water runs off inside the device, the device must not be tilted sideways, backwards or forwards. Otherwise electronic components inside can be damaged!

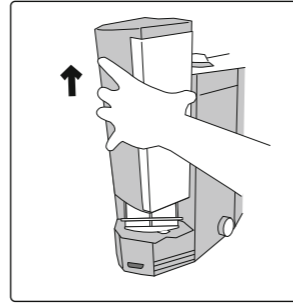

3. Pour approx. 1 liter of warm, clean drinking water at about 30-40 °C in a container and dissolve approx. 100-200 g of citric acid (E330) therein. The solution should be very acidic so that limescale deposits can be completely dissolved.
4. Connect the thin end of the tube from the descaling set to the descaling pump. Insert the thicker part of the tube into the opening on the ECAIA ionizer S, where filter No. 2 was installed.

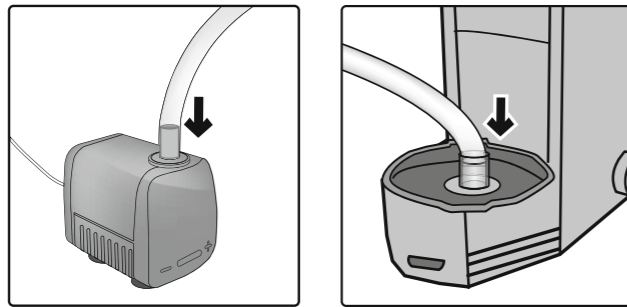

5. Connect the descaling pump to the power supply. The pump starts automatically.

Note: Occasionally the pump may not start immediately due to repeated use and insufficient cleaning. No reason to panic. If this is the case, most likely the propeller wheel is glued to the pump housing. Give the pump a "jump start" by carefully poking a screwdriver into the opening of the pump and trying to loosen the adhesive on the propeller wheel. The wheel should then spin again.

6. Immerse the pump in the container with the descaling solution. The solution is sucked in by the pump and pumped into the ECAIA ionizer S. Make sure that the pump is positioned a few centimeters above the bottom of the container so that dissolved limescale is not sucked in again by the pump and flushed back into the device.
7. Position the outlets for the alkaline (A-2) and acidic water (A-3) so that they flow into the container with the descaling solution and thus the descaling solution can flow back into the container (check that the descaling solution flows out of both openings). This creates a closed circulation. The descaling solution should be flushed through the device for several hours in order to completely dissolve all limescale deposits and flush them out.

8. To stop descaling, disconnect the power supply to the descaling pump by pulling out the power plug. Make sure that the entire descaling solution flows completely back into the container. If you place the container a little below the device, a "suction effect" is created which draws out all of the liquid.
9. Remove the descaling tubing and completely dry the excess water with a clean, absorbent cloth.
10. Place the left filter No. 2 back in, as described under point "3.2 - Filter replacement".
Tip: To ease the filter future removal, apply an oily liquid onto the seals, e.g. Vaseline.
11. Reconnect the device to the power supply and turn it on. Press the PURIFY button (B-26) and let the water flow through it for approx. 1-2 minutes so that all residues of the descaling liquid are completely rinsed out.
12. The ECAIA ionizer S can then be placed in normal service again. If necessary, check the ionization performance using the pH testing liquid, as described in the point "1.13 - Control of ionization output performance".

Note: If there is heavy calcification, the display of the device may not switch on after restarting. The reason for this is limescale sediment that was not completely dissolved, pumped back into the device and blocked the flow meter inside the device. Perform descaling again until all the limescale is completely dissolved and rinsed out. The display should switch on again.

Tip: Prevent possible bacterial contamination and impurity by adding food-safe disinfectant to the descaling liquid. SANUSLIFE INTERNATIONAL recommends the use of ECAIA+ allhygienics, available in the SANUSSTORE.

Descaling of ECAIA ionizer S+ in combination with ECAIA ionizer S faucet:

The descaling process works in the same way as described above. However, the descaling solution should also flow through the ECAIA ionizer S faucet. This requires positioning of the container with the descaling solution in the sink so that both outlets (E and F) of the 2-way fitting of the ECAIA ionizer S faucet open into the container. To be able to connect the descaling pump to the device, as explained under point 4 of the descaling description, you need a longer descaling tubing. This was provided free of charge with the ECAIA ionizer S faucet.



How To Videos - Descaling Videos on the respective descaling processes can be found on YouTube under the search term "Descaling ECAIA ionizer".

4.3 Cleaning and disinfection

If the device is contaminated with germs or bacteria as a result of improper use, we recommend cleaning it thoroughly with a disinfectant.

Proceed as described under point "4.2 - Descaling". In such a case use, instead of water with dissolved citric acid, 1 liter of drinking water with disinfectant, which is also suitable for disinfecting food.

SANUS**LIFE** INTERNATIONAL recommends the use of ECAIA+ allhygienics, available in the SANUS**STORE**.

In the event of serious pollution, please contact the service support in the respective country.

5 Safety instructions

- Only use the specified voltage of AC 230V / AC (or 120V / AC for the USA model), otherwise there is a risk of causing fire or electrical damage.
- The fuse of the device has 2 amps. Do not use any other fuse than the one specified, otherwise malfunctions or damage may be caused. Should a malfunction occur, pull out the power plug immediately and discontinue the use of the device.
- Do not touch the device or the control panels with wet hands. Doing so could result in electric shock.
- Plug and unplug the power cable with the connector, do not pull on the cable. Otherwise, the cord could be damaged resulting in electric shock or fire.
- Avoid tangling the cables. Do not share the socket with other devices; this would cause overheating and could result in fire.
- A damaged power cord or plug could cause a short circuit. Do not damage, alter, entangle, or pull the power cord with extreme force. Do not staple the cable. This may result in an electric shock.
- If dust or dirt has accumulated on the casing, please unplug it and clean it. Excess debris could start a fire.
- If the device accidentally falls into the water, immediately:
 1. unplug.
 2. remove the device out of the water.
 3. contact service support.
- Do not attempt to amend, take apart, or repair the device. Otherwise, it could cause fire or result in an electric shock. Neither the manufacturer nor the sales company can be held liable for such actions and subsequent consequences. All warranty services shall be automatically void in such a case.
- Do not place anything on the device.
- Do not place the device in places where it is exposed to vibrations.
- Do not expose the device to direct sunlight. This could lead to increased formation of microorganisms.
- Protect the device from sub-zero temperatures. Such action could freeze the water inside and cause damage. The filter performance can also be negatively influenced.
- Avoid contact with heat or fire. Doing so could deform the casing or cause internal damage.
- Do not use or store the device in places with high humidity.
- The tubing for ionized acidic water should not be higher than the position of the water flow rate regulator (B-3). Too long, bent or positioned higher tube may affect the ionization or the taste of the water.

- Do not lift the device by the filter cover. The filter cover could come off and the device could fall and / or break. Only lift the device by the bottom.
- Never tilt the device forwards, backwards or to the side when in use. This could cause electronic components inside the device to get wet or damaged! It should stand up straight or be attached to the wall.
- If the device falls, internal parts may be damaged. If so, please contact service support to have the device checked.
- If no water is drawn for a period of more than 12 hours, it is recommended to let the water run for at least 30 seconds before the next use.
- If the device is not used for a longer period of time, there is a risk of formation of microorganisms. Therefore, the device should be thoroughly cleaned and the filters replaced before being used again.

6 Error and problem handling

Check the options below to resolve possible problem or errors. If this is ineffective, please contact the service support.

Error messages	Causes and Solutions
ERROR 1 or 2	Power fluctuations - can occur due environmental factors. Contact your electricity provider.
ERROR 3	Overheating of the electrolysis chamber - switch off the device. Carry out descaling of the device.
ERROR 4 or F	The water pressure is too high - reduce the flow rate until the bars on the flow rate display (B-21) are in the "normal" range.
ERROR 7	Self-cleaning was interrupted prematurely - allow the device to finish self-cleaning.
ERROR 8	The filters are not inserted correctly, the cable on the filter is not connected correctly, or no original ECAIA filters are used.
Water is leaking out of the bottom of the device.	<ul style="list-style-type: none"> • Check the connections. • If water spills out when changing the filter, it will flow out of the bottom of the device.
The display no longer lights up after descaling.	The flow meter was probably blocked by limescale sediment. Perform descaling procedure again.
The water has a strange taste.	<ul style="list-style-type: none"> • Check the pH value. Too high pH value may change the taste. • The device might be dirty. Clean and disinfect. • The filter capacity has been reached, replace the filters. • Make sure that the lower 7/9 mm outlet tube (A-4) is not bent.
Very little water flows out of the device and / or the device periodically fails to switch on.	<ul style="list-style-type: none"> • Check the setting of the water pressure on the water flow regulator or on the T-piece. • Carry out descaling of the device. • Replace the filters. • Clean or replace the filter for tap water supply hose 1/4" and / or the water pressure reducing valve on the tap water supply hose 1/4".

Initially water always comes out warm.	The remaining water in the device is heated by the ambient temperature. Only once the cool water flows in from the main pipeline and the individual parts in the device have cooled down, the device produces cold water.
No water flows out of the lower water outlet.	<ul style="list-style-type: none"> • Make sure that the plastic hose for acidic water 7/9 mm (A-4) is not bent. • Make sure that the flow rate is in the normal range. • Carry out descaling of the device.
The water does not alkalinize.	<ul style="list-style-type: none"> • Check that sufficient amount of acidic water is draining off. • Reduce the flow rate. • Set the ionization performance in the sub-menu to maximum power. • Carry out descaling of the device.

7 FAQs

Here you will find important information that will answer many unresolved questions. If you have any questions that have not been answered below, please read the FAQs section on the website at faq.sanusproducts.com.

Should you still have any questions, please contact the support team of SANUSLIFE INTERNATIONAL. You can find the contact information on the website www.sanusproducts.com

7.1 When should you measure the pH value of the ECAIA water?

Various factors may influence the ionization performance. We therefore recommend that all of our customers measure the pH value not only at the beginning, i.e. after the first use, but also in the following days / weeks, after every filter replacement and every descaling.

7.2 Does the ECAIA ionizer S also work with hard water?

Yes. The ECAIA ionizer S also works with hard water. The ionization performance can be set individually and adapted to the respective water hardness.

7.3 Does the ECAIA ionizer S also work when using a descaling system?

Yes. The ECAIA ionizer S also works when using a descaling system.

Note: A descaling system is usually an ion exchanger. Calcium ions are replaced for sodium ions. This is convenient for various household appliances because it means they are less calcified. Drinking water should not run through the descaling system, as large amounts of sodium could cause health problems. Neither sodium nor calcium are filtered out by the ECAIA ionizer S.

7.4 What is the ORP value or the redox potential?

The ORP value (redox potential) expresses the ability to acquire or lose electrons. This value is expressed in mV (millivolts): If the water is negatively charged, it means that it is rich in electrons and has antioxidant properties; If, on the other hand, the water is positively charged, then it is electrons deficient and therefore has oxidative properties. While the water from the tap has an oxidative property (approx. + 300mV), the ECAIA water has antioxidant properties (from approx. -50mV to -500mV). A high lime content can also influence the redox potential. Furthermore, the

redox potential fluctuates. Over time, the ORP value fluctuates back into the positive range and the water becomes oxidative again. It is therefore advised to only produce as much water as you intend to drink.

7.5 Can bacteria accumulate in the ECAIA ionizer S and thus contaminate the water?

The ECAIA filters are delivered packed dry and sealed. Contamination can only result from incorrect care or improper handling of the ECAIA ionizer S. You should therefore always ensure absolute sterility around the device. Avoid touching the output tube with dirty hands, organic substances such as food, dirty washcloths or other "bacteria carriers". Bacteria can multiply rapidly, especially in the warm seasons of the year. Please also note the tips under point "4.2 - Descaling" and point "4.3 - Cleaning and disinfection".

7.6 Does the ECAIA ionizer S also filter limescale?

No. The ECAIA ionizer S filters many pollutants such as chlorine, heavy metals, microparticles, VOCs, herbicides, pesticides, fungicides, hormones and drug residues. Important minerals such as calcium, magnesium, sodium, etc. are preserved in the water. This following is the specialty of the ECAIA ionizer S: While conventional filter systems often filter out too little, others filter out "everything", turning it into distilled or osmosis water, the ECAIA ionizer S only filters the pollutants.

7.7 White residue or deposits form on glassware. How can that be?

The water treated with the ECAIA ionizer S is ionized. Consequently, the minerals contained in the water are negatively charged. But since containers made of plastic or glass are positively charged, the negatively charged minerals are increasingly attracted and stick to glasses and decanters. This creates these white residues or deposits. However, since these are purely natural deposits, they can also be easily removed. This can be done by simply adding a little citric acid or vinegar to the water, leave it on for a few minutes and then rinse with clean water. Consequently, every container looks like new again!

7.8 What happens if you drink too much ECAIA water? Can it have negative effects on health?

No. The ECAIA water is like any other water, the only difference is that it has been filtered and is also alkaline, antioxidant and rich in oxygen. Please note, however, that the body must first adapt to the ECAIA water. Give the body time to get used to the "new" water by starting with a low pH value and increase gradually.

7.9 Hardly any water comes out of the faucet, what can I do?

There can be several reasons for this:

- The descaling was not carried out correctly, not in-depth or not regularly, the outlet tubing for the alkaline, ionized water is clogged with limescale sediment. You can check this by unscrewing the "Alkaline water flexible discharge hose (A-2)" and control whether large amounts of limescale have deposited. Carry out descaling of the device.
- The small filter for tap water supply hose 1/4" (A-7) and / or the water pressure reducing valve (C-13), which was inserted between the tap water supply hose 1/4", is blocked. Clean or replace the sieve.
- If the device is mounted on the T-piece, check the setting of the water pressure as described under point "1.11 - Flow rate configuration".

7.10 Why does warm water flow out of the ECAIA ionizer S?

There is always some residual water in the device, which can heat up due to the ambient temperature. Once you switch on the device, it will take some time for all heated parts to cool down and for cool water to flow.

7.11 Is it possible to use own water source?

Yes. Make sure, however, that the water quality of the source complies with drinking water quality requirements.

8 Technical specifications

Product name		Water ionizer
Model		ECAIA ionizer S / ECAIA ionizer S+
Protection type and class		Class 2, type B device
Drinking water protection standard		DIN EN 1717; Category 1
Voltage		AC 230V (US model AC 130V) 50 Hz / 130 W
Water supply		Connection to the faucet or angle valve
Device	Dimensions	320 X 150 X 380 (W x D x H in mm)
	Weight	Approx. 6.5 kg
Water pressure		0.7 - 6.0 bar
Allowed temperature		5 - 25°C
Protection		Built-in temperature sensors: 2 sensors (automatic shutdown)
Electrolysis	Method	Continuous electrolysis
	Capacity	1.5 l / min. (with a water pressure of approx. 2 bar), including ionized, alkaline and acidic water
	Stages	Alkaline 5 levels / acidic 2 levels
	Cleaning	Automatic electrode polarity reversal. First model series also self-cleaning (time: approx. 30 seconds; flushing out: approx. 0.2 l)
	Electrodes	7 titanium, platinum coated electrodes
Filter	Shelf-life	Filter no. 1: approx. 1,800 l; Filter no. 2: approx. 3,600 l (max. 6 months)
	Display	LC flow rate display
	Material	Non-woven material, activated carbon granulate, calcium sulfite, sediment (pre-filter) and UF membrane filter
Function		Filtration and treatment of drinking water
Manufacturing license		KFDA (Korea Food and Drug Administration) Registered manufacturing No. 889
Product license		KFDA product license No. 09-696

9 Warranty and guarantee



Warranty & guarantee

Dear customer,

Congratulations on your purchase of the ECAIA ionizer S flow-through ionizer. We assure you that you have made an excellent choice. The ECAIA ionizer S was made from the highest quality materials. Therefore, you can rest assured that with the ECAIA ionizer S you have a top-quality device and you will enjoy it for a long time if used properly. We value your satisfaction with the device, and therefore we grant you an extended, voluntary guarantee of 4 years in addition to the mandatory warranty period of 2 years. To avoid confusion and to ensure a smooth service, please carefully read and observe the following information.

Support Case Procedure

1. First contact the service support of SANUSLIFE INTERNATIONAL. If the problem cannot be resolved, please fill out the enclosed "Customer Service Form" in as much detail as possible.
2. Please send your ECAIA ionizer S (at your own expense) together with the "Customer Service Form" in suitable transport packaging (no liability shall be accepted for unforeseen damage during transport) to SANUSLIFE INTERNATIONAL or the relevant partner company in your country. You can find the addresses on the SANUSLIFE INTERNATIONAL website at the foot of the page under SUPPORT.
3. The device will be checked and repaired by our technician and if the repair is classified as a warranty or guarantee case, it will be returned to you free of charge.

Warranty and guarantee

- A total of 6 years from the invoice date.
- The warranty & guarantee includes free repairs of existing material and manufacturing defects after delivery.
- The claims must be asserted immediately to SANUSLIFE INTERNATIONAL within the deadline.
- This guarantee applies to the first owner and can be transferred in the event of resale, provided the new customer is registered with SANUSLIFE INTERNATIONAL and recorded as the new owner.

Important information

Warranty and guarantee do not extend to the calcification of the device. A descaling set is sent free of charge when you order the ECAIA ionizer S. The exact description and the recommended frequency of the descaling process is described in detail under point "4.2 Descaling". The warranty and guarantee also exclude all damage caused by improper use, maintenance, overuse, pollution and natural wear and tear.

Furthermore, please note that the filters, regardless of individual use, must be replaced at least every 6 months from the first use. Improper handling can lead to the accumulation of germs or bacteria in the device. SANUSLIFE INTERNATIONAL assumes no liability for this and reserves the right to reject all warranty and guarantee claims in these cases (even within 6 years period), as this type of contamination can only be caused by the user's own fault. A warranty and guarantee claim is also excluded if the cause of the defect was knowingly or unknowingly caused by intervention of the user, especially when trying to repair the device himself.

10 Customer service form



Customer service form

Please fill it in fully and legibly.

Information on the applicant:

Customer ID No.: _____	_____
Last name: _____	First name: _____
Street: _____	ZIP code / city: _____
Phone.: _____	Country: _____
Mobile: _____	E-Mail: _____
Return delivery address (only fill in if another delivery address exists):	
Last name: _____	First name: _____
Street: _____	Country / ZIP code / city: _____

Information on the guarantee claim:

- Yes, date of purchase _____ (Guarantee certificate or invoice required)
- No, I am hereby placing a repair order up to an amount of _____ EUR (including VAT, excluding shipping)

If the repair costs are not covered by the guarantee and exceed the specified maximum limit, we will contact you.

Product information:

Product name: _____ Serial No.: _____

Error Description:

Please describe the errors that occur in as much detail as possible, you may also attach photo or video.

Should we have any questions about the defect, we can contact you at:

Phone: _____ Time: _____

Place / date: _____ Signature: _____



You can find this document on the SANUSLIFE INTERNATIONAL website www.sanusproducts.com at the foot of the page under SUPPORT.

Accessories:

Applies when shipping water ionizer. Please only send us the faulty device. Remove all tubes and connectors. Ensure that no water can escape from the device. Turn the rotary knob to "Off" and close the 2 openings (outlet for alkaline and acidic water) with a plug. Remove the filters, plug the gaps with an absorbent paper towel and put the filter covers back on.

If the error relates to an accessory or the filters, please send them to us as well. The following additional parts are included:

Important Note: We assume no liability for accessories that are not listed!

Packaging and shipping:

It is best to pack the product in the original box and send it in a sturdy, standard packaging box. SANUSLIFE INTERNATIONAL assumes no liability for shipping damage.

Once the product arrives, it is immediately checked for any damage that can be attributed to improper use or packaging or as a result of the latter during transportation. Costs for damage caused by improper packaging are always covered by the customer. This applies in particular to damage caused by residual water leaking from the device during transport.

Please send the product to the following address:

EU: SANUSLIFE INTERNATIONAL GmbH
Via Luigi Negrelli 13/C,
39100 Bolzano (I)
Italy

Switzerland: Mr. Ernst Salvisberg
Trottenstrasse 14
8180 Bülach
Switzerland

The cost of shipping the product to SANUSLIFE INTERNATIONAL is covered by the customer. SANUSLIFE INTERNATIONAL covers the costs for the return shipment, provided it is an actual guarantee case.

Place/ date: _____ Signature: _____

IMPORTANT!

- Please enclose a copy of the entire repair order in the package!
- Please send another copy to SANUSLIFE INTERNATIONAL by email:

E-mail: support@sanusproducts.com



You can find this document on the SANUSLIFE INTERNATIONAL website www.sanusproducts.com at the foot of the page under SUPPORT.

11 Certificates



Certificates for ECAIA ionizer S

All valid certificates for the ECAIA ionizer S can be found under the "Documents" tab in the download area of the SHOP article on the SANUSLIFE INTERNATIONAL website www.sanusproducts.com.



Water Treatment Device

International sales through:

SANUSLIFE INTERNATIONAL GmbH
Via Luigi Negrelli 13/C, 39100 Bolzano (I)
Tel.: +39 0471 979998
www.sanusproducts.com – support@sanusproducts.com

